



Installation Instructions

ELEKTROMAT

SE 5.24 WS-25,40

Model: 10003424 10012

-en-

Status: 30.05.2018



GfA ELEKTROMATEN GmbH & Co. KG
Wiesenstraße 81
D-40549 Düsseldorf
🌐 www.gfa-elektromaten.de
✉ info@gfa-elektromaten.de

Table of contents

1	General safety information	4
2	Technical Data	5
3	Mechanical installation	6
4	Electrical installation	10
5	Limit switch adjustment	11
6	Motor connection	12
7	Limit switch connection	12
8	Emergency manual operation (rapid hand chain operator)	13
9	Completing commissioning / inspection.....	15
10	Declaration of incorporation / conformance	16

Symbols



Warning - Potential injury or danger to life!



Warning - Danger to life from electric current!



Note - Important information!



Requirement - Required action!

Schematic representations are based on product examples. Deviations from delivered products are possible.



1 General safety information

Specified normal use

The drive unit is intended for sectional doors with full counter-balancing.

The safe operation is only guaranteed with normal specified use. The drive unit is to be protected from rain, moisture and aggressive ambient conditions. No liability for damage caused by other applications or non-observance of the information in the manual.

Modifications are only permitted with the agreement of the manufacturer. Otherwise the Manufacturer's Declaration shall be rendered null and void.

Safety information

Installation and initial operation tasks are to be performed by trained, skilled fitters only.

Only trained electrical craftsmen are permitted to work on electrical equipment. They must assess the tasks assigned to them, recognise potential danger zones and be able to take appropriate safety measures.

The installation is only to be carried out with the supply off.

Observe the applicable regulations and standards.

Coverings and safety devices

Do not operate unless corresponding coverings and safety devices are fitted/installed.

Ensure that gaskets are correctly positioned and cable glands are correctly tightened.

Spare parts

Use only original spare parts.

2 Technical Data

Type	KG 50	
Output torque	50	Nm
Output speed	24	rpm
Output shaft / hollow shaft	25,40	mm
Maximum holding torque	200	Nm
Maximum door weight	2500	N
Supply voltage	1N~ 230	V
Operating current	3,50	A
Operating frequency	50	Hz
Power factor $\cos \varphi$	0,99	
Maximum movement per hour	12	h ⁻¹
Class of protection	IP 65	
Limit switch range (maximum revolutions of output shaft / hollow shaft)	20	
Temperature range	-10 / +40 (+60)	°C

1) When using a temperature range of +40°...+60°C use half of maximum movements per hour.

3 Mechanical installation

Prerequisites

The permissible loads on walls, fastenings, mountings and transmission elements must not be exceeded, even for maximum holding torques or locking torques (► refer to technical data).

Connection elements:

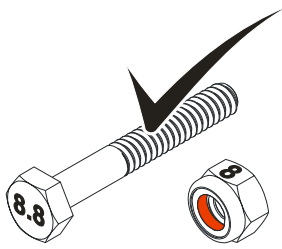
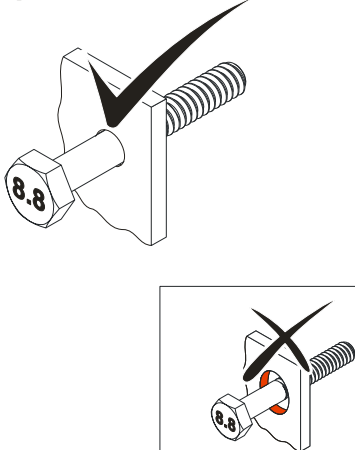
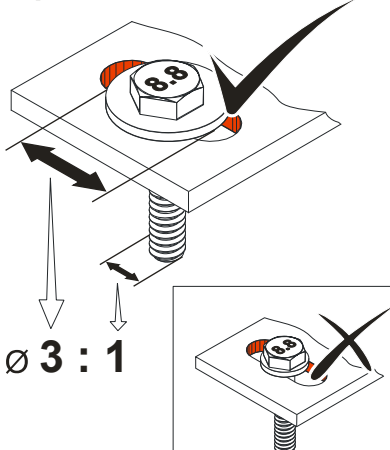
<ul style="list-style-type: none"> ► Self-locking connection elements with a minimum strength of 800 N/mm² (8.8) must be used. 	<ul style="list-style-type: none"> ► Utilize the hole diameter to the full. 	<ul style="list-style-type: none"> ► Use adequately dimensioned washers for elongated holes.
<p><small>BAGAB00001_2002</small></p>  <p>≥ 800 N/mm²</p>	<p><small>BAGAB00002_2002</small></p> 	<p><small>BAGAB00003_2002</small></p>  <p>Ø 3 : 1</p>

Permissible mounting positions

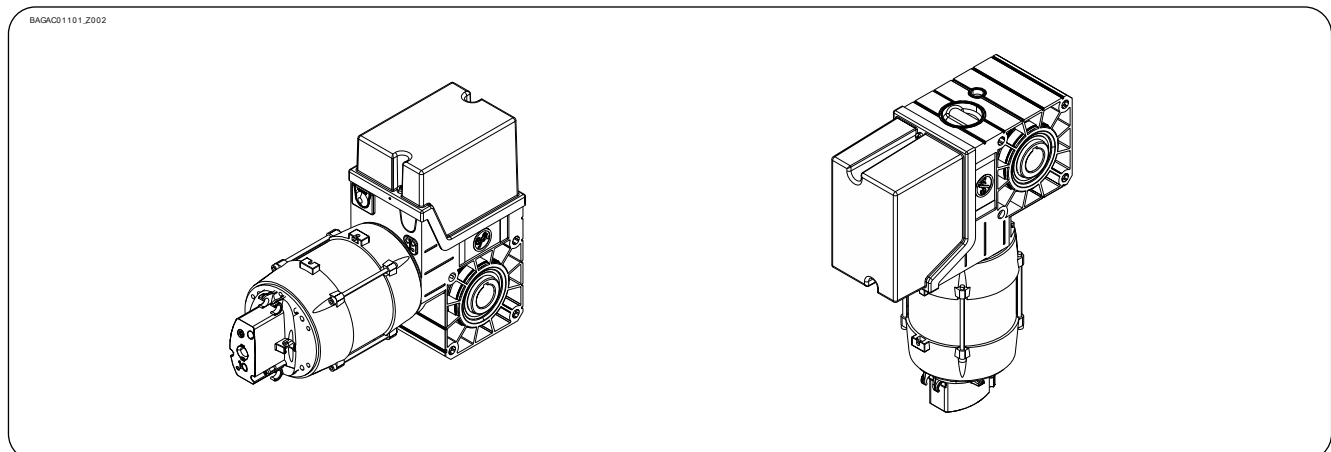

Mounting

Three holes are provided for mounting.

- ▶ Use at least 2 of these (①).
- ▶ Use the connection elements supplied (②).

Keys are used to connect to the door shaft.

- ▶ Use a key that is at least as long as the hollow shaft (③).

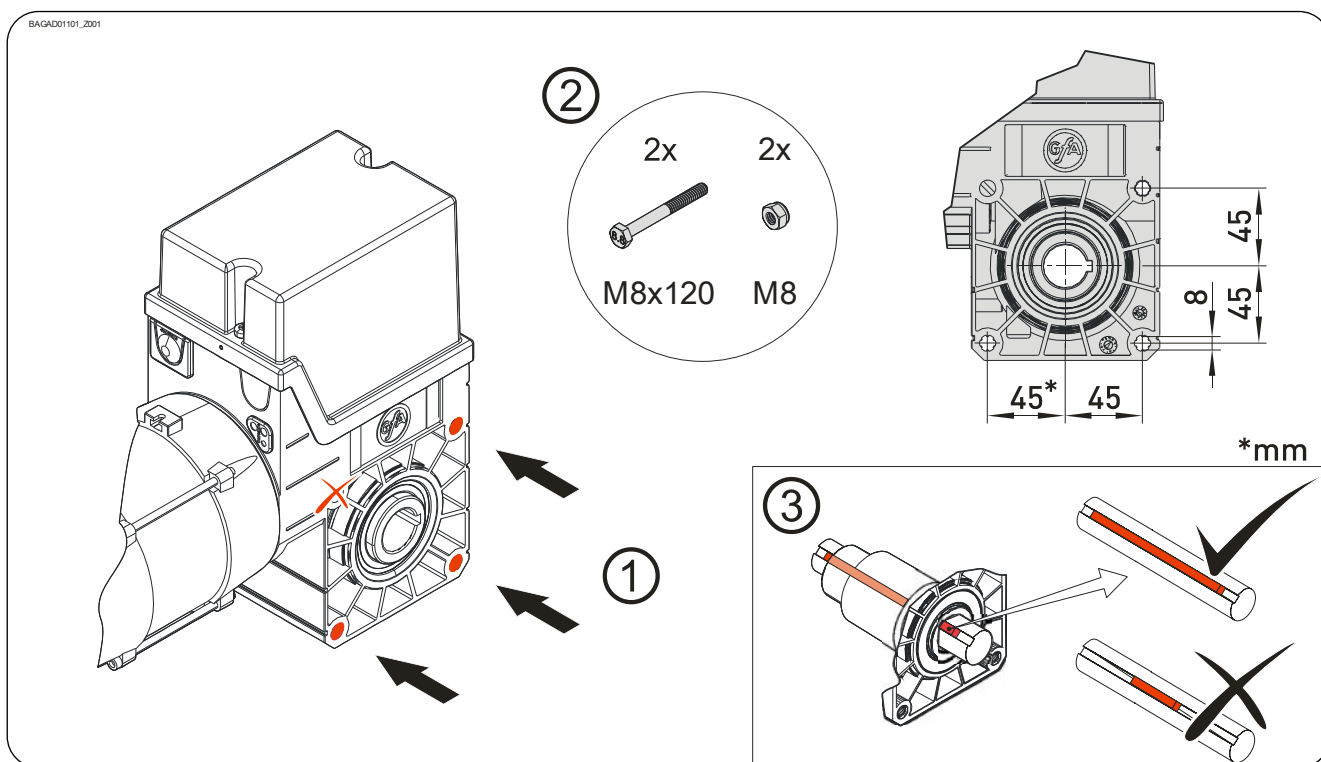

Installation

The descriptions below apply to general door specifications. The specifications of the door manufacturer must also be observed during installation.



Warning - Potential injury or danger to life!

- During installation, be sure to use a lifting device that has a sufficient load-carrying capacity.

- ▶ Thoroughly grease the door shaft.

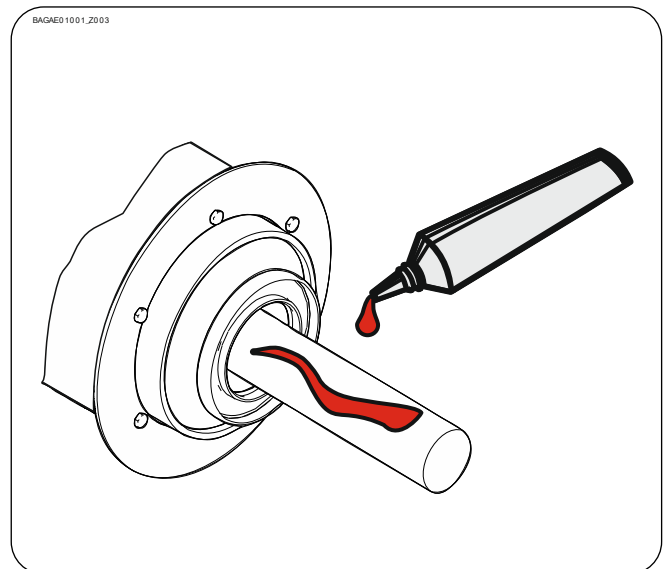

- ▶ Mount the keys. Observe possible variants
Ⓐ or Ⓑ.

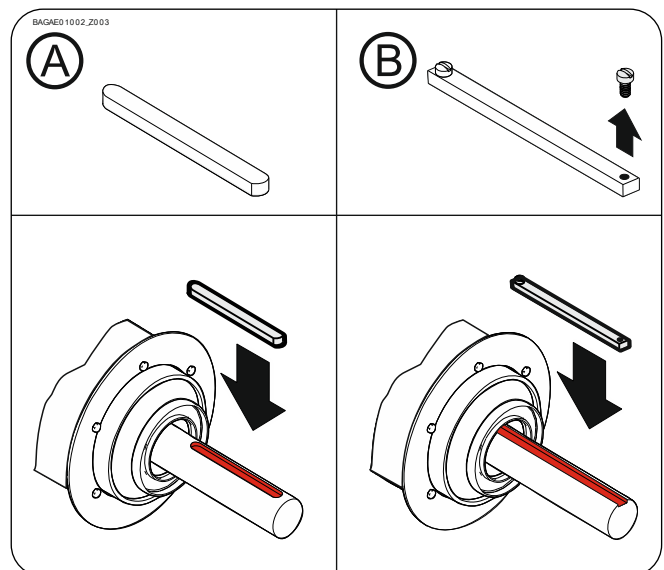

- ▶ Attach the drive unit.

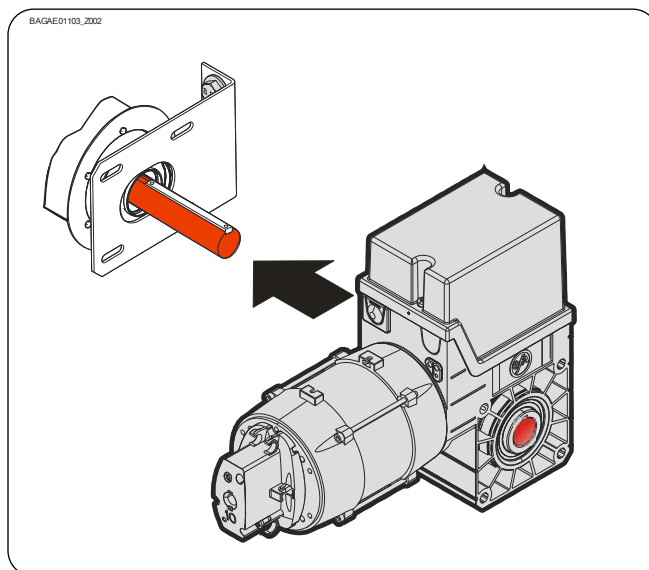

- ▶ Tighten all connection elements on the drive (M8) to 25 Nm. Install all other connection elements according to the specifications of the door manufacturer.

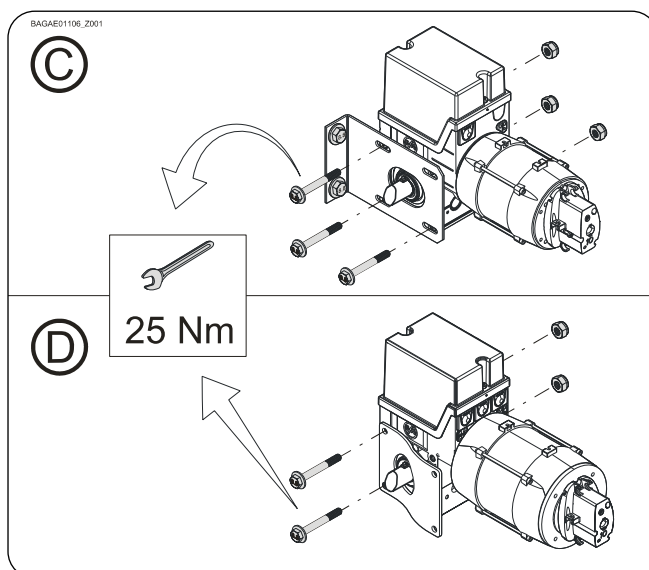

- ▶ Secure the keys (version ② only).

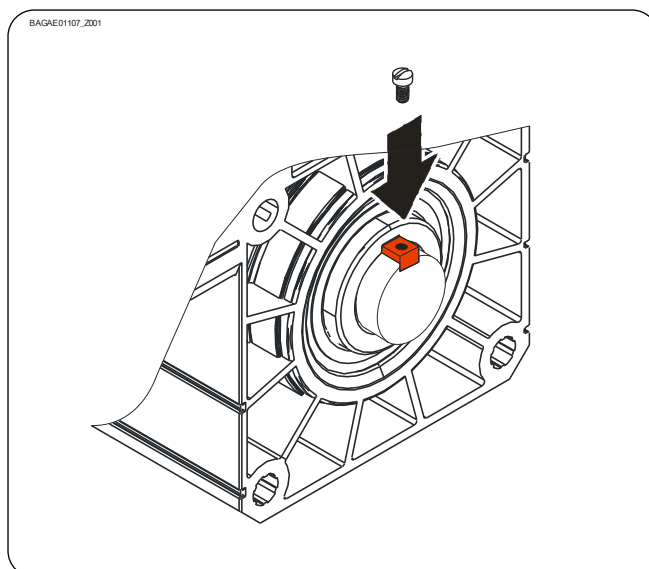

4 Electrical installation



Warning - Danger to life from electric current!

- Switch the mains OFF and check that the cables are de-energised
- Observe the applicable regulations and standards
- Make a proper electrical connection
- Use suitable tools

Performing electrical installation

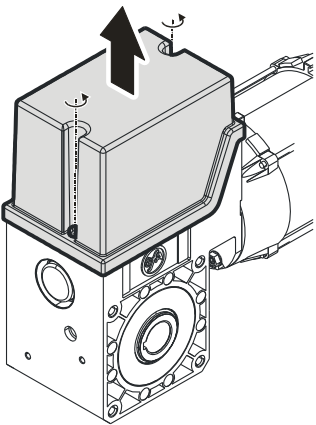
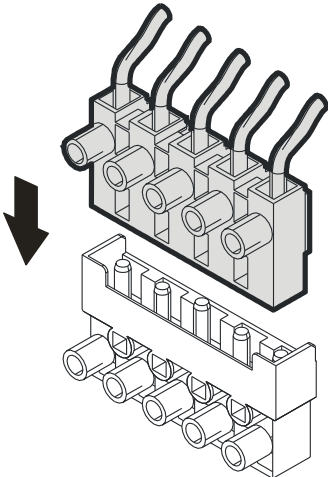
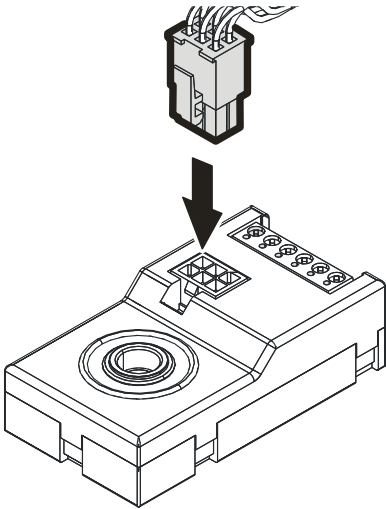
Remove the cover.	Insert the motor plug.	Insert the limit switch plug.
<p>BAHA01_L2001</p> 	<p>BAH80_L2001</p> 	<p>BHAC 13_2001</p> 

Completing the electrical installation

Mount the cable entries and/or cable glands.

5 Limit switch adjustment

The adjustment of the final limit positions OPEN and CLOSE is described in the instructions for the door control panel.

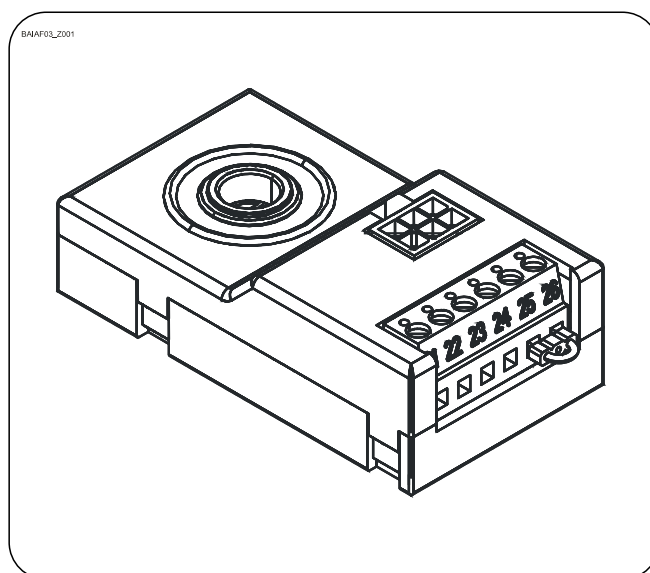

6 Motor connection

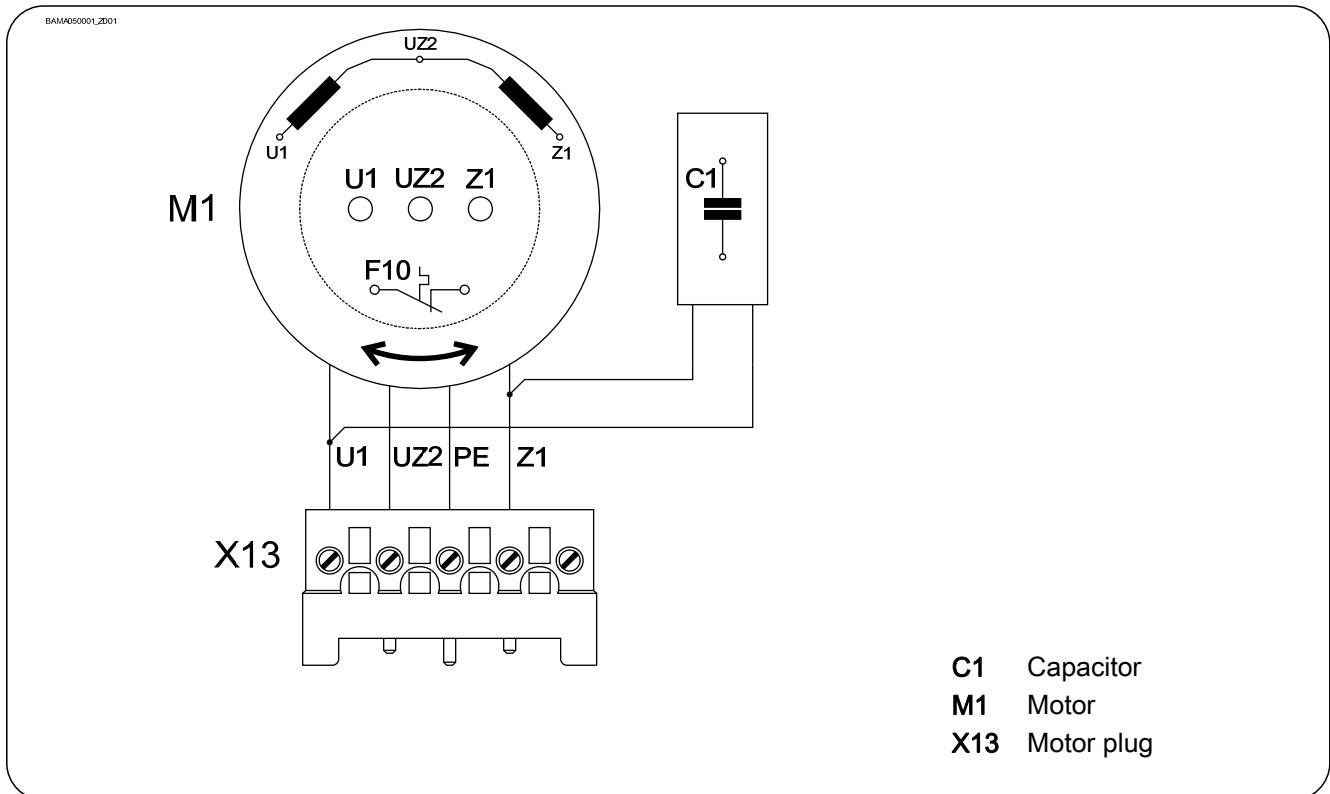

7 Limit switch connection

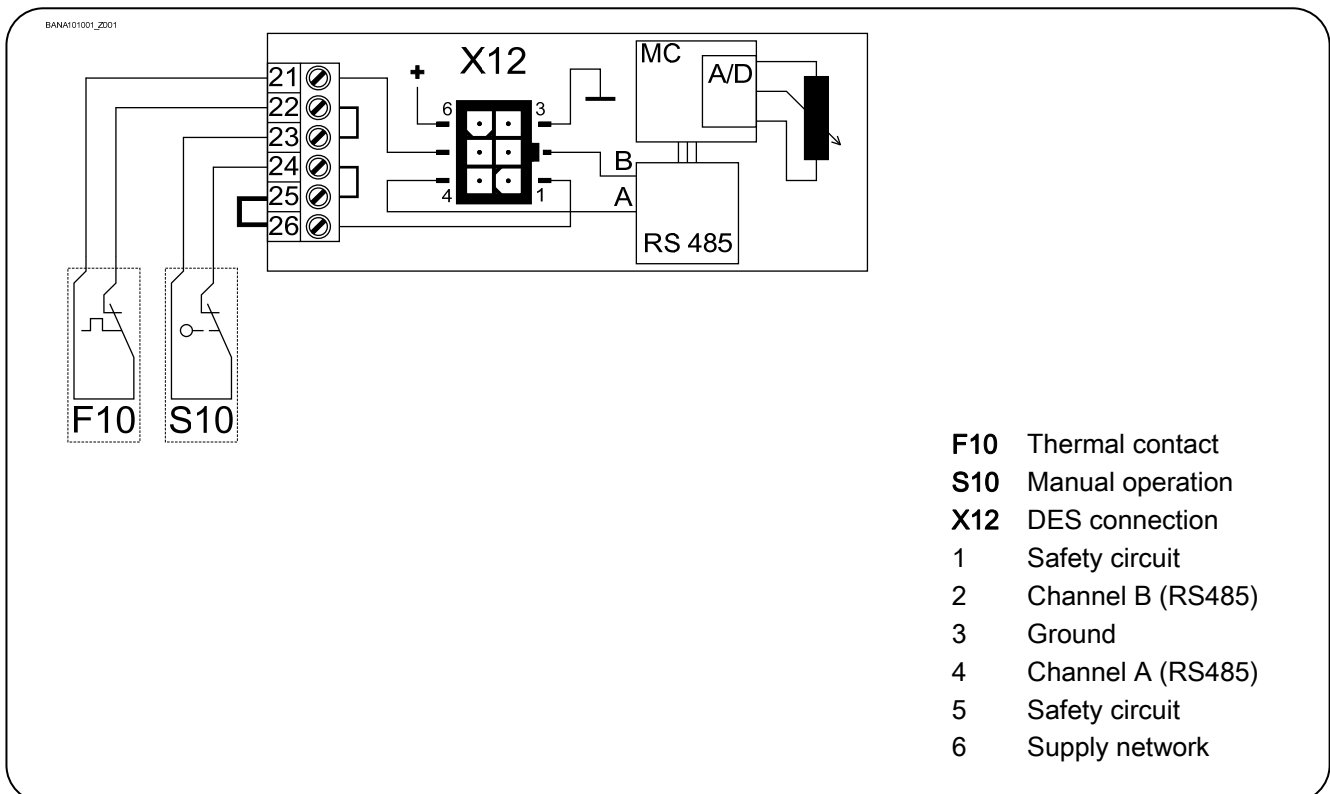

8 Emergency manual operation (rapid hand chain operator)

Emergency manual operation is designed for opening or closing the door without power supply. Its activation interrupts the control voltage. Electrical operation is no longer possible.



Warning – Injuries due to incorrect operation!

- Switch off voltage.
- Adopt a secure position.
- For drive units with brake, the emergency manual operation must be carried out against the closed brake.



Warning - Danger of the door dropping!

If you need to apply more than the permissible force of 390N (according to DIN EN 12604/DIN EN 12453) to move the door by emergency manual operation, this indicates a stalling on the drive unit or door. Releasing the stalling may cause the door to drop.

- Adopt a secure position.
- For drive units with brake, the emergency manual operation must be carried out against the closed brake.



Caution – Damage to components!

- Do not move the door beyond the final limit positions.

Switch on by pulling the red handle. Open or close by pulling the chain. Switch off by pulling the green handle.

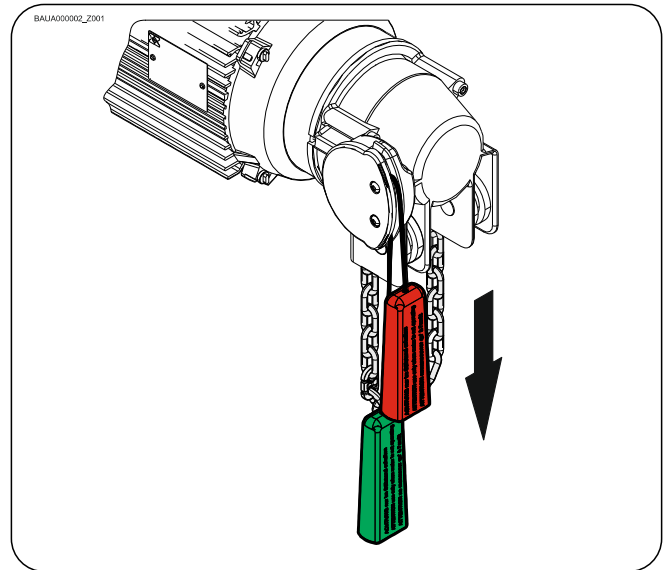

9 Completing commissioning / inspection

Check the following components and then install all covers.

Gearbox

Check the drive unit for loss of oil (a few drops can be neglected). Protect the output-shaft permanently against corrosion.

Mounting

Check that all connection elements (consoles, torque mounts, screws, locking rings, etc.) are secure and in proper condition.

Electrical wiring

Check the connection cables and cabling for damage or crushing. Check that the screw connections and plug connections are fitted properly with a good electric contact.

Emergency manual operation

Check the function with the power disconnected. Perform the check only between the final limit positions.

Limit switch

Check the final limit positions by opening and closing fully. The safety area must not be approached.

Drive unit



Note!

- Engage a qualified engineer to check the drive unit annually
- Apply shorter inspection intervals for doors that are operated frequently
- Observe the applicable regulations and standards

Declaration of incorporation

in the terms of Machinery Directive 2006/42/EC
for partly completed machinery, Appendix II Part B



Declaration of conformity

in terms of EMC Directive 2014/30/EU

GfA ELEKTROMATEN GmbH & Co. KG
Wiesenstraße 81 · 40549 Düsseldorf
Germany

We, the
GfA ELEKTROMATEN GmbH & Co. KG
hereby declare that the following products are conform with the above
EC Guideline and are only intended for installation in door equipment.

SE 5.24 WS-25,40

Standards applied

DIN EN 12453:2001-02	Industrial, commercial and garage doors and gates - Safety in use of power operated doors - Requirements
DIN EN 12604:2000-08	Industrial, commercial and garage doors and gates - Mechanical aspects - Requirements
DIN EN 60335-1:2012-10	Household and similar electrical appliances - Safety - Part 1: General requirements
DIN EN 61000-6-2:2006-03	Electromagnetic compatibility (EMC) Part 6-2 Generic standards – Immunity standard for industrial environments
DIN EN 61000-6-3:2011-09	Electromagnetic compatibility (EMC) Part 6-3 Generic standards – Emission standard for residential, commercial and light-industrial environments

We undertake to transmit in response to a reasoned request by the appropriate regulatory authorities the special documents on the partly completed machinery.

Authorised representative for the compilation of the relevant technical documents

(internal EU address)
Dipl.-Ing. Bernd Synowsky
Documentation representative

Incomplete machines within the meaning of the EC Directive 2006/42/EC shall only be intended to be integrated into other machines (or into other incomplete machines/systems) or to be assembled with them to form a complete machine within the sense of the Directive. Therefore, this product cannot be commissioned before it is determined that the entire machine/system to which it was integrated shall comply with the provisions of the Machinery Directive indicated above.

Düsseldorf, 10.07.2017

Stephan Kleine
CEO

Signature